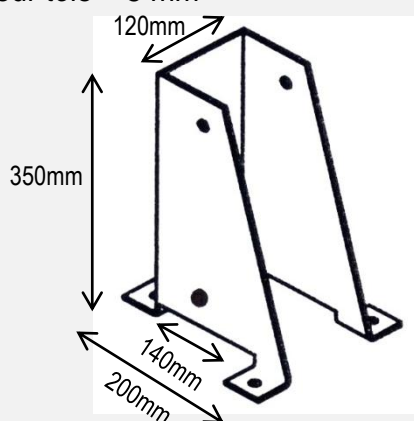

Protection de Rayonnage

Protection de face : Réf B370S (5 kg)

Gencod : 3234640036717

Epaisseur tôle = 5 mm

**Protection d'angle : Réf B371S (5 kg)**

Gencod : 3234640036724

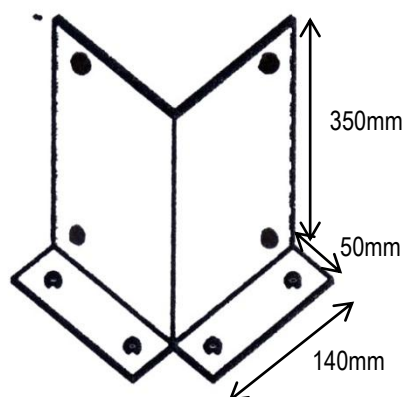
**Traverse de protection : 2 modèles :**

- Réf **B372S** : longueur 0.850m
Réglable de 0.9 à 1.350m.(9kg)
Gencod : 3234640036731
- Réf **B373S** : longueur 1.800m
Réglable de 1.85 à 2.75m (17.5kg)
Gencod : 3234640036748

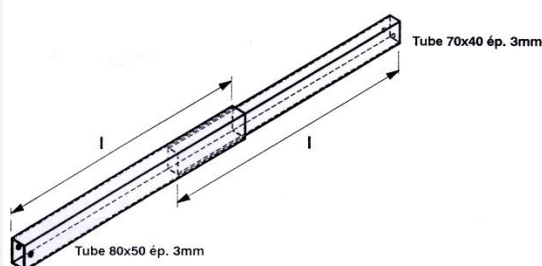
**Cheville métallique par expansion**Réf **B374S10** diamètre 10 x 90

Gencod : 3234640036755

