

A710P - Remorque pour vélo

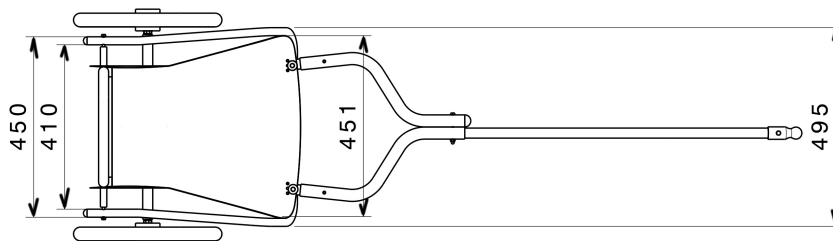

Conception et fabrication française

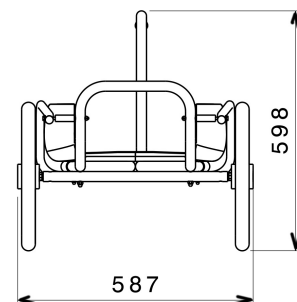
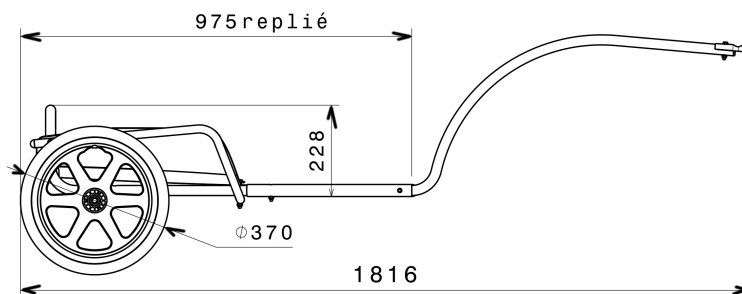
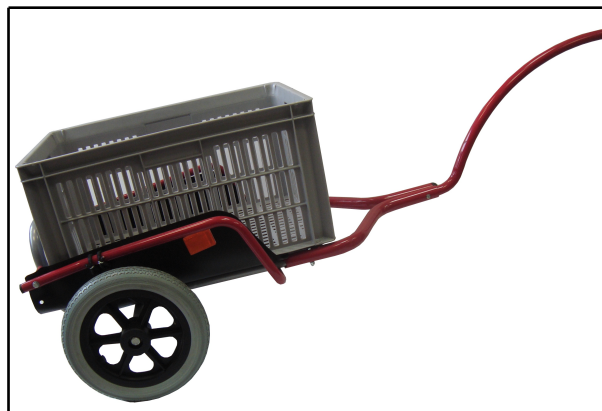
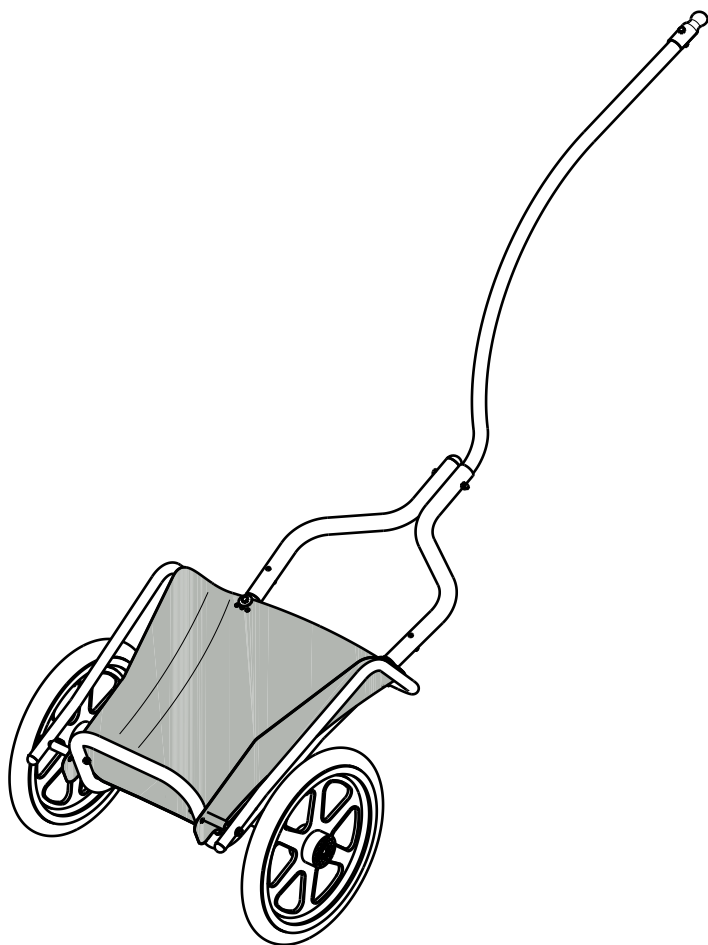

SAV



Si malgré toutes les précautions prises lors de la conception du produit, vous deviez rencontrer un problème, notre Service Après Vente reste à votre disposition. Du lundi au jeudi : de 8h00 à 17h00 et le vendredi de 8h00 à 15h00



33 (0)3 20 10 90 25



be-sav@mottez.com













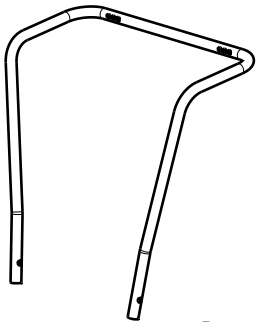
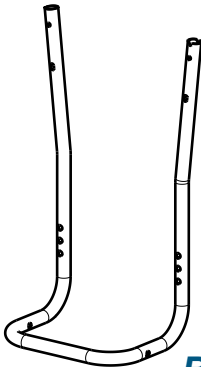
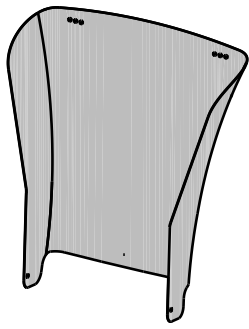
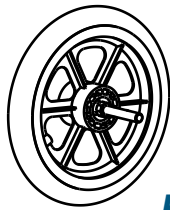
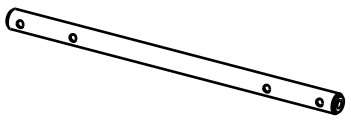



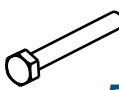





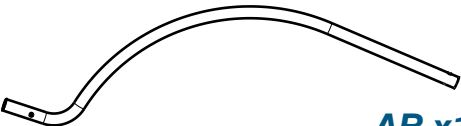

33 (0)3 20 10 37 89



<http://www.chariotderandonnee.com>

CONA710P 19038

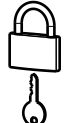
Lire impérativement la notice avant toute utilisation

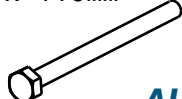
| | | | | | | | | | |
|--|--|---|--|---|--|---|--|---|--|
|  A x1 | |  B x1 | |  C x1 | |  F x2 | |  G x1 | |
|  T x2 | |  U x6 | |  V x2 | |  J x2 | |  P x2 | |
|  W x2 | |  X x6 | |  Y x2 | |  R x2 | | | |
|  AA x2 | |  AB x1 | |  AC x2 | |  AD x1 | |  AE x1 | |
|  AF x1 | |  AG x1 | |  AH x2 | |  AI x1 | |  AJ x2 | |
|  AM x2 | |  AN x2 | |  AO x1 | |  AP x1 | |  AL x2 | |

1/. Montage de l'essieu

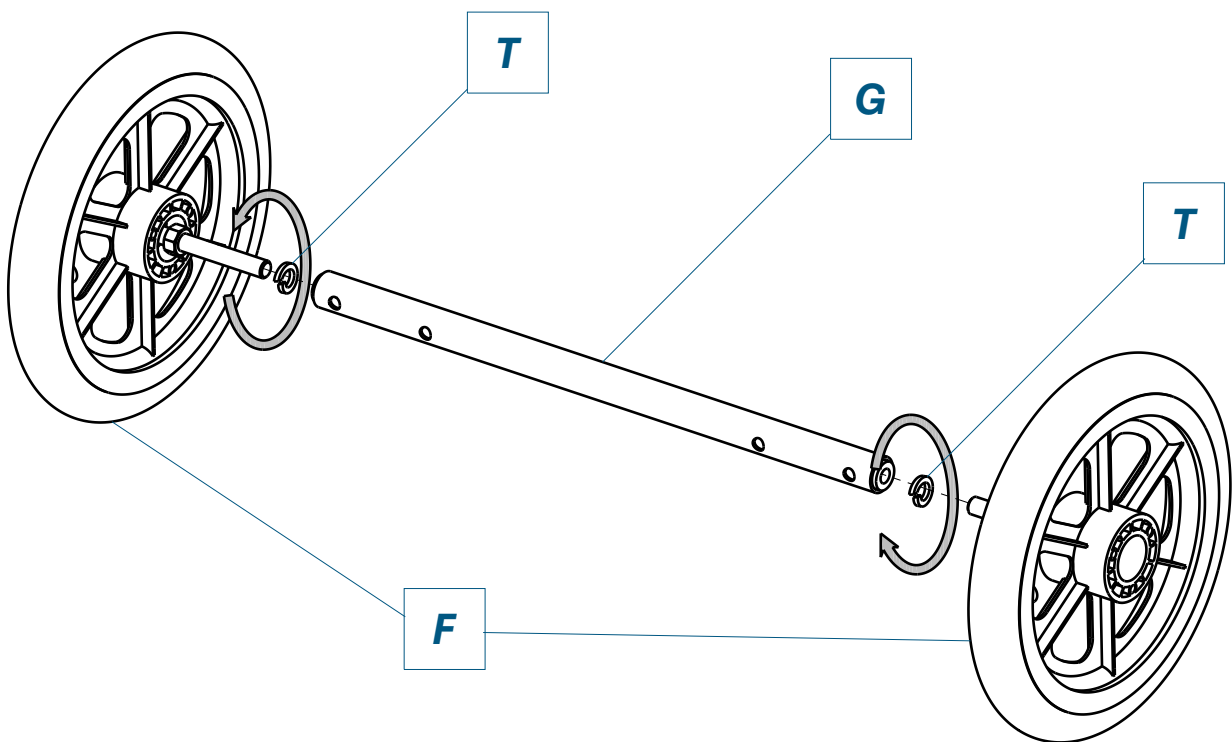

Bloquer fortement

2/. Montage de l'armature

3 positions pour avoir un écart entre les bras plus ou moins important

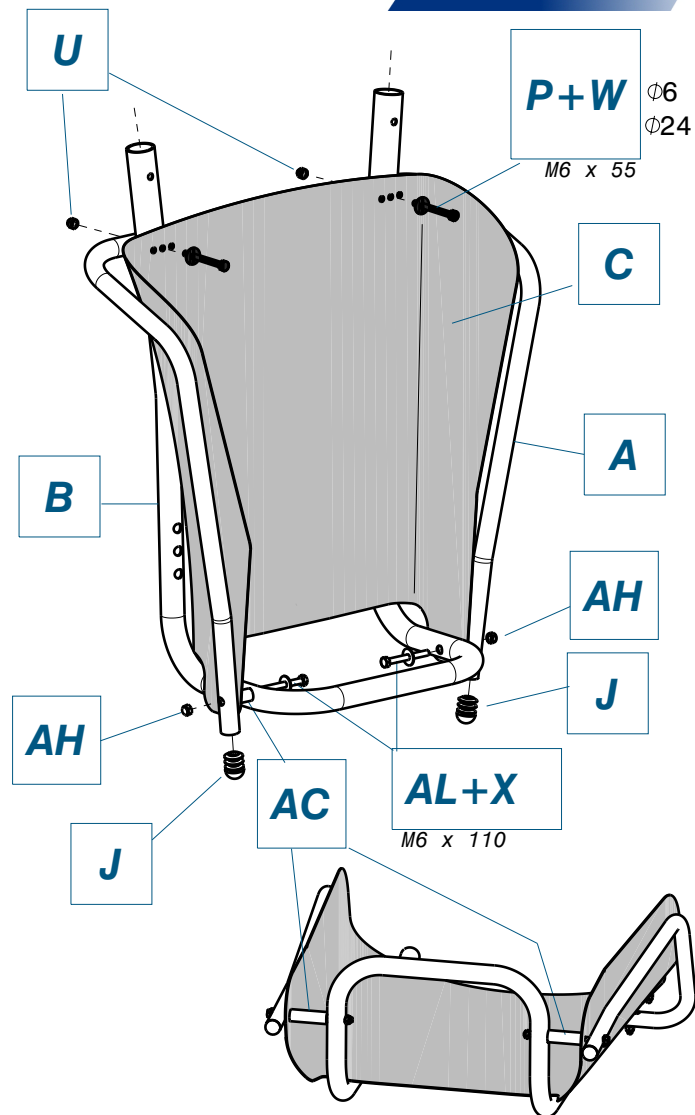
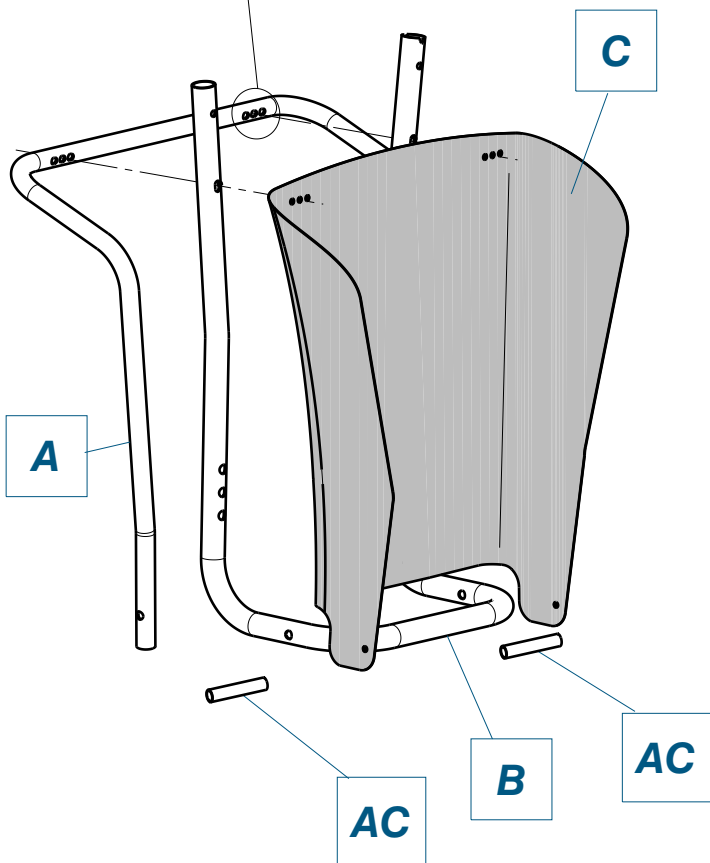

3/. Montage de l'armature sur l'essieu

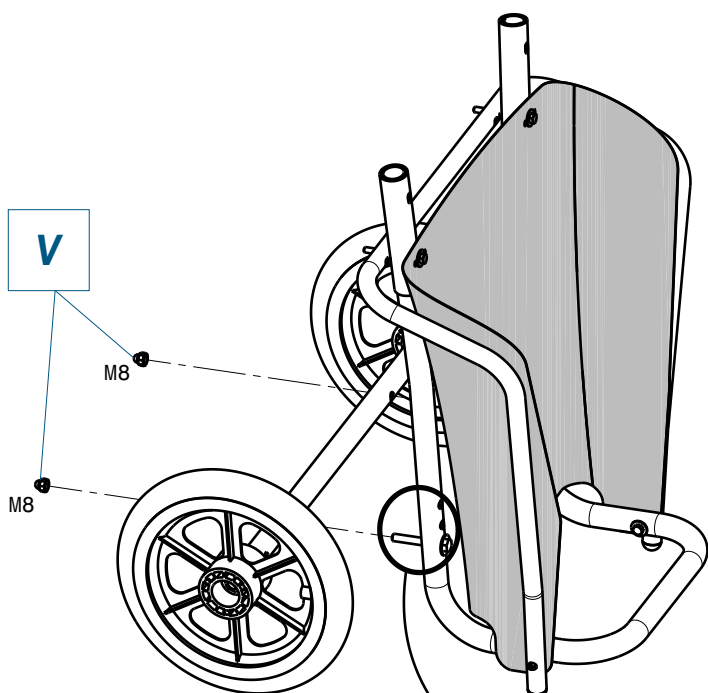

3 positions possibles à adapter en fonction de la charge. Veuillez positionner l'essieu comme ci-dessous pour la charge maxi.

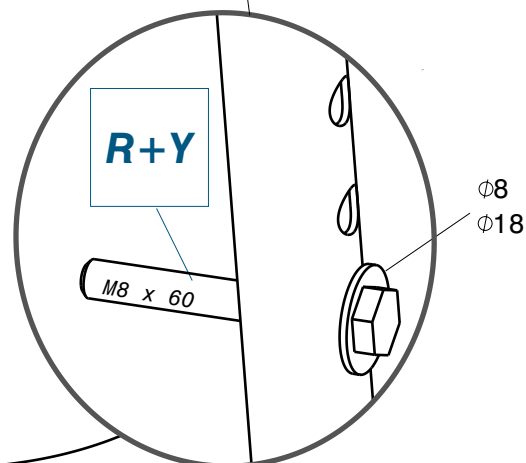

4/. Montage de l'armature supérieure

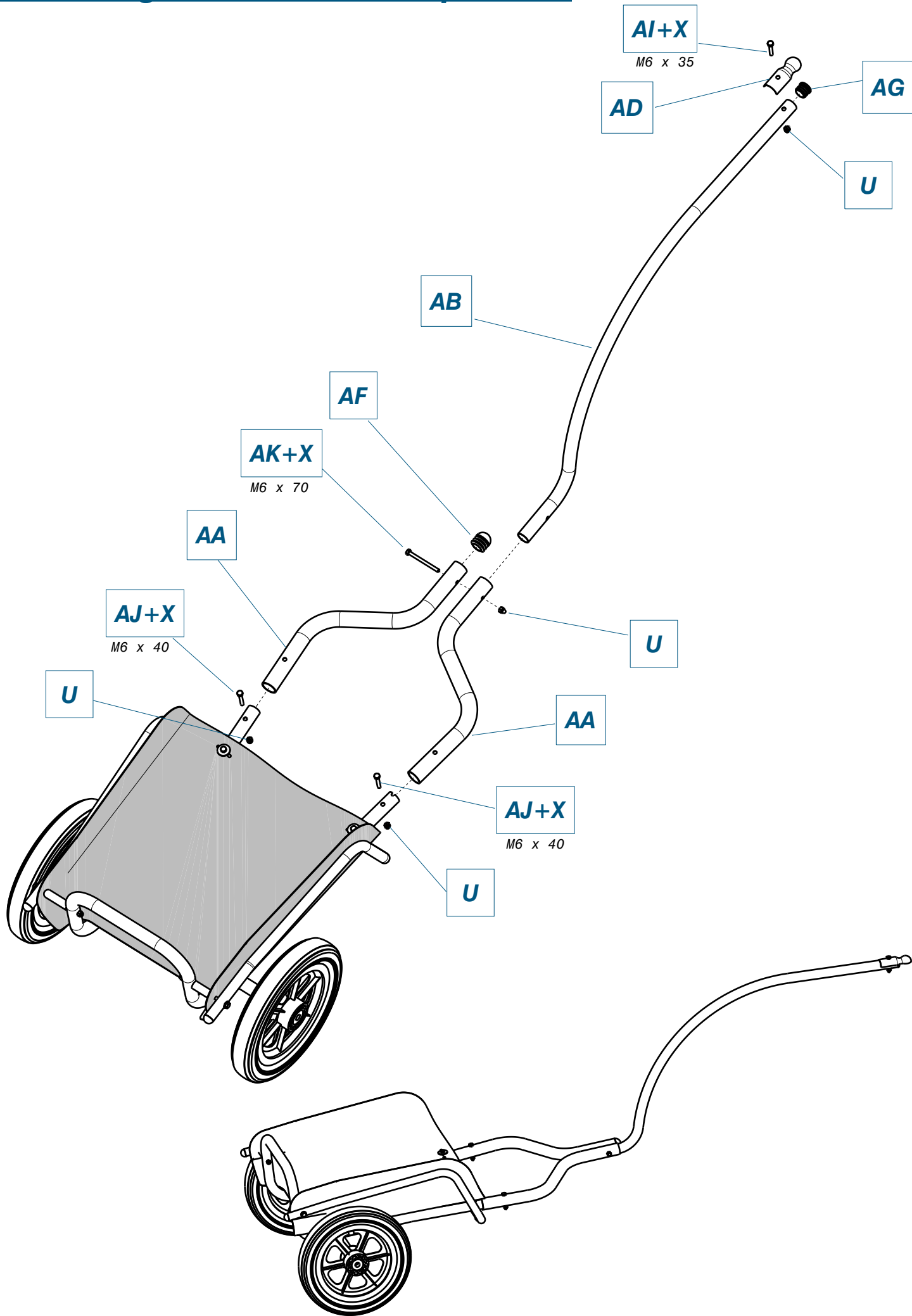

5/. Montage du produit sur le vélo

MOTTEZ



6/. Fixation des sandows

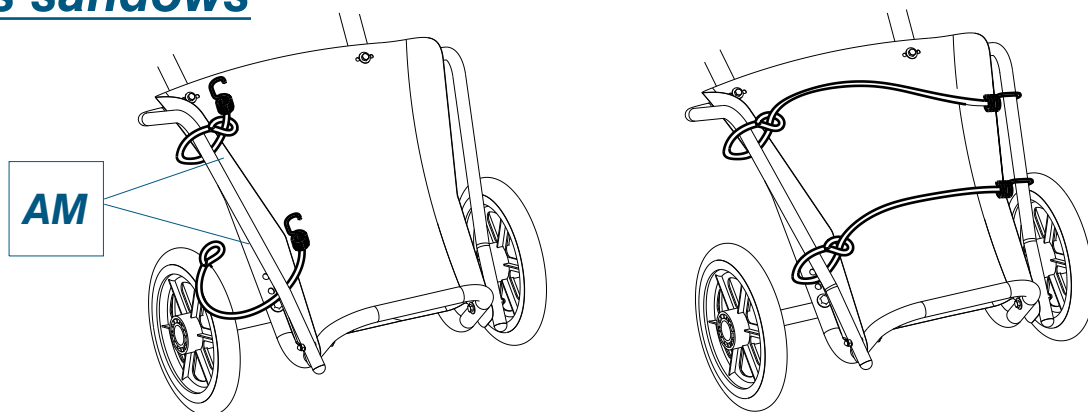

7/. utilisation du produit



A n'utiliser que de jour. La nuit, équiper le produit d'un dispositif d'éclairage rouge à l'arrière.

30 kg
maxi.

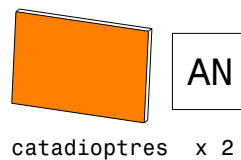

catadioptrés x 2