

Wall Scooter Rack for 9 Scooters



Photo non contractuelle

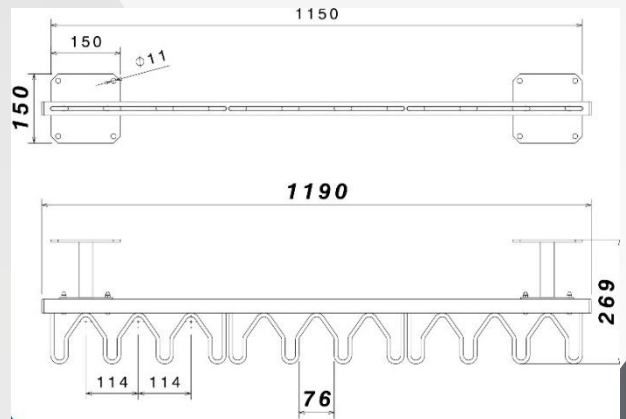

Photo non contractuelle

- Store up to 9 scooters !
- Possibility to fix a cable lock or U-lock (Diameter hole for the lock: Ø22mm)
- The “V” shape of the scooter stem holder hook allows an efficient blocking of the scooters
- The serpentine shape allows to fix a cable lock or U-lock
- Wall fixing with 2 brackets, 30 mm square tube with 15 x 15 cm square plate for fixing (fixing not supplied)

Technical Description

- Material : Multi layer paint with anti rust treatment , 1 anti corrosion layer + 1 anthracite grey epoxy powder paint layer
- Dimensions : 119 x 27 x Height 15 cm
- Attachment plate 15 x 15 cm – fixing holes Ø 11 mm
- Serpentine tube Ø 8 mm
- Square tube 30/2 mm
- Weight : 5,80 kg



Mottez Article Code

Article Code : **M509SMUR**
EAN Code : 3234640061931

% of recycled material in the product	70 %
% recycled product in packaging	100 %
Hazardous substance > 0.1%	No
Repairability Index	10 / 10
Recyclable product	Yes