

# Storage Rack for 6 Scooters + 3 Bikes

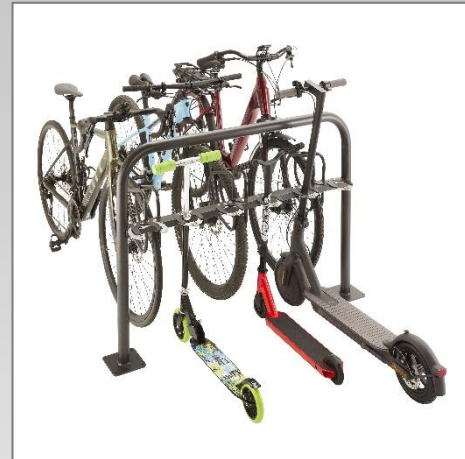
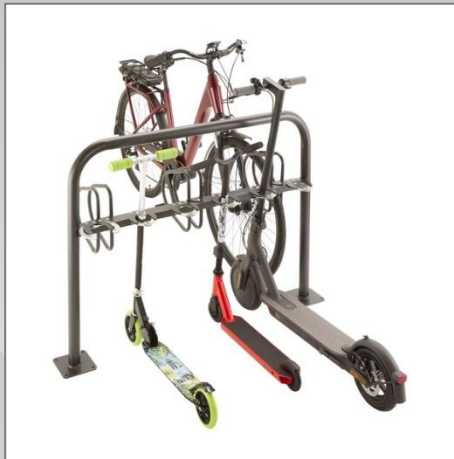

- Allows you to store 6 scooters on one side and 3 bikes on the other.
- Scooter stems are held by a clip pinching system that can be secured by a cable lock or U lock (not supplied) – allows scooter stems Ø 70 mm max
- The bike side device allows the bike to be held by the front wheel and secured by an anti-theft device.
- Ground bolting by means of 2 attachment plates 15cmx15cm (fixings not supplied)

## Technical Description

- *Material* : steel tube Ø 50 mm anthracite black polyester powder paint – antirust + light grey clips
- *Scooters* : Ø of the hole for the lock : 20 mm
- *Attachment plate* 15 x 15 cm with 4 fixing holes Ø 11 mm
- *For wheels max.* 55mm (for the bikes)
- *Recommended fixation*: 8 screws for floor fixing (not supplied)
  - For concrete floor: plastic dowels Ø 10 mm, minimum length 60 mm
  - For tarmac floor: chemical seal dowels Ø 10 mm max (as Ø 11 mm holes)
- *Bike racks*: tube Ø 16 mm, thick. 1 mm (delivered unassembled) with anti-theft system
- *Dimension* :
  - Useful : 126 x 43 x Height 93 cm
  - Overall: 136 x 43 x Height 93 cm
  - Weight : 23 kg

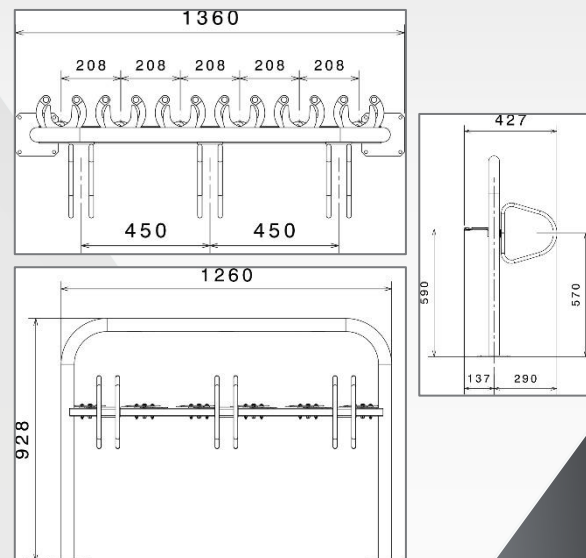

## Mottez Article Code

Article Code : **M093C**  
EAN Code : 3234640063324

% of recycled material in the product	70 %
% recycled product in packaging	100 %
Hazardous substance > 0.1%	No
Repairability Index	10 / 10
Recyclable product	Yes

